

# Standard models

Motor type	H series motor
Model number	103H32 □□ /103H52 □□ /103H67 □□ /103H71 □□ /103H78 □□
Insulation class	Class B (130°C)
Withstand voltage	□28 (□1.10inch) · □42 (□1.65inch) : AC500V 50/60Hz for 1 minute, □50 (□1.97inch) · □56 (□2.20inch) · □60 (□2.36inch) : AC1000V 50/60Hz for 1 minute
Insulation resistance	100M ohm MIN. against DC500V
Vibration resistance	Amplitude : 1.52mm (p-p) , 147m/s <sup>2</sup> , frequency range : 10 to 55Hz, sweep time : 5minutes, number of sweep is 12 times each in the X, Y and Z directions.
Impact resistance	Acceleration : 98m/s <sup>2</sup> , holding time : 11ms, half-wave sine wave 3 times in each direction of X, Y, and Z axes, 18 times in total.
Operating ambient temperature	-10°C to 50°C
Operating ambient humidity	90%MAX. : 40°C MAX., 57%MAX. : 50°C MAX., 35%MAX. : 60°C MAX. (no condensation)

Motor type	SH series motor
Motor model number	SH353 □□ , SH142 □□ , SH160 □□ , SH286 □ ,
Insulation class	Class B (130°C)
Withstand voltage	□35 (□1.38inch) · □42 (□1.65inch) : AC500V 50/60Hz for 1 minute, □60 (□2.36inch) / □86 (□3.38inch) : AC1000V 50/60Hz for 1 minute
Insulation resistance	100M ohm MIN. against DC500V
Vibration resistance	Amplitude : 1.52mm (p-p) , 147m/s <sup>2</sup> , frequency range : 10 to 55Hz, sweep time : 5minutes, number of sweep is 12 times each in the X, Y and Z directions.
Impact resistance	Acceleration : 98m/s <sup>2</sup> , holding time : 11ms, half-wave sine wave 3 times in each direction of X, Y, and Z axes, 18 times in total.
Operating ambient temperature	-10°C to 50°C
Operating ambient humidity	90%MAX. : 40°C MAX., 57%MAX. : 50°C MAX., 35%MAX. : 60°C MAX. (no condensation)

Motor type	SM series motor
Model number	SM286 □
Type	S1 (continuous operation)
Insulation class	Class F (+155°C)
Operation altitude	1000m (3280 feet) MAX above sea level
Withstand voltage	□86mm (□3.39inch) : AC1500V 50/60Hz for 1 minute
Insulation resistance	100M ohm MIN. against DC500V
Protection grade	IP40
Vibration resistance	Amplitude of 1.52mm (0.06inch) (P-P) at frequency range 10 to 500Hz for 15 minutes sweep time along X, Y, and Z axes for 12 times.
Impact resistance	490m/s <sup>2</sup> of acceleration for 11 ms with half-sine wave applying three times for X, Y, and Z axes each, 18 times in total.
Ambient operation temperature	-10 to +50°C
Ambient operation humidity	90% MAX. at less than 40°C, 57% MAX. at less than 50°C , 35% MAX. at 60°C (no condensation)

# Allowable radial / thrust load

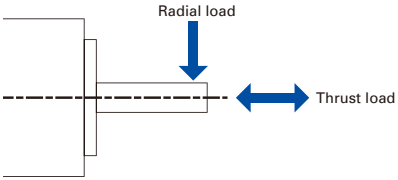

Frang size	Model number	Distance from end of shaft : mm (inch)				Thrust load N (lbs)
		0	5 (0.20)	10 (0.39)	15 (0.59)	
□28mm (□1.10inch)	103H32 □□	30 (6)	38 (7)	53 (11)	84 (18)	3 (0.67)
□35mm (□1.38inch)	SH353 □	40 (8)	50 (11)	67 (15)	98 (22)	10 (2.25)
□42mm (□1.65inch)	103H52 □□ 103-59 □ SH142 □	22 (4)	26 (5)	33 (7)	46 (10)	10 (2.25)
□50mm (□1.97inch)	103H670 □	71 (15)	87 (19)	115 (25)	167 (37)	15 (3.37)
□56mm (□2.20inch)	103H712 □ 103H7128	52 (11)	65 (14)	85 (19)	123 (27)	15 (3.37)
□60mm (□2.36inch)	103H782 □ SH160 □	70 (15)	87 (19)	114 (25)	165 (37)	20 (4.50)
□86mm (□3.39inch)	SM286 □ SH286 □	167 (37)	193 (43)	229 (51)	280 (62)	60 (13.488)
φ 86mm (φ 3.39inch)	103H822 □	191 (42)	234 (52)	301 (67)	421 (93)	60 (13.488)
φ 106mm (φ 4.17inch)	103H8922 □	321 (72)	356 (79)	401 (90)	457 (101)	100 (22.48)

# CE marked models

Model Number	103H712 □	103H822 □ / 103H8922 □
Rated voltage	12-200VDC	12-300VDC
Applied standards (Low voltage directive)	EN60034-1, IEC34-5(EN60034-5), EN60204-1, EN60950, EN61010-1	
Operation type	S1 (continuous rating)	
Protection grade	IP43	
Device category	Class I	
Operation environment	Pollution degree 2	
Insulation class	Class B (130°C)	
Insulation resistance	Not less than 100M Ω between winding and frame by DC500V megger or normal temperature and humidity.	
Withstand voltage	Without abnormality when applying 50/60Hz, 1600V AC (1500V AC for 103H712 □) for 1minute (leakage current 10mA) between winding and frame at normal temperature and humidity.	
Ambient operation temperature	-10 to +50°C	
Ambient operation humidity	90% MAX. at less than 40°C, 57% MAX. at less than 50°C , 35% MAX. at 60°C (no condensation)	
Winding temperature rise	80K MAX. (Based on Sanyo Denki standard)	

# Internal Wiring and Rotation Direction

## Unipolar winding

### ● 103H32 □□ Connector type

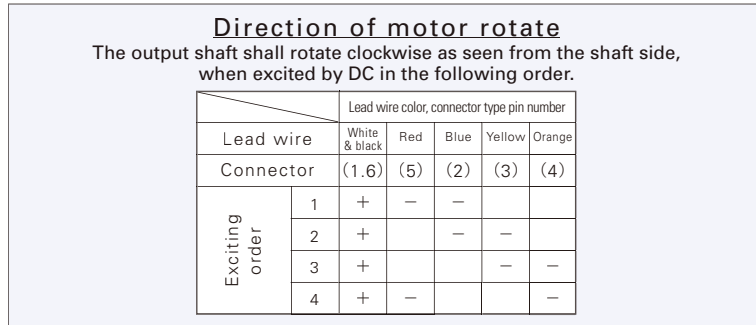
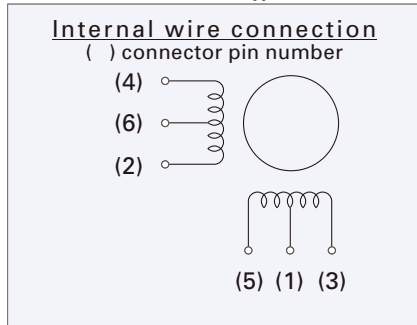

### ● 103H52 □□ Connector type

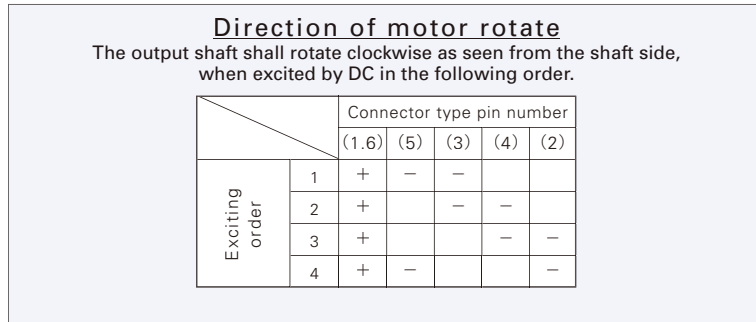
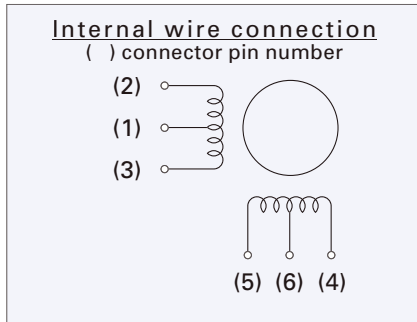

### ● 103H782 □ Connector type

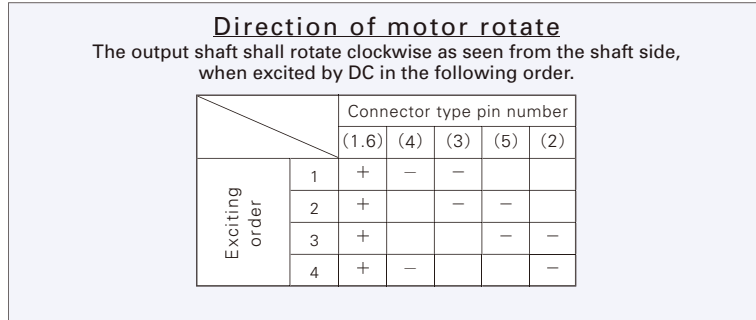
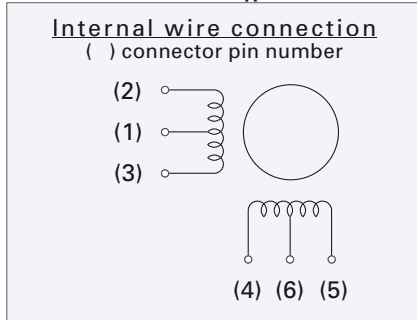

### ● Lead wire type

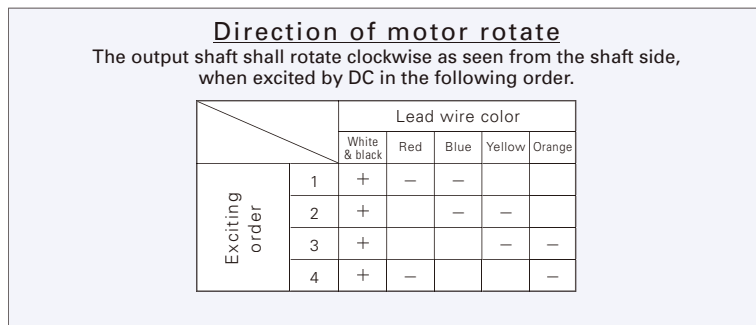
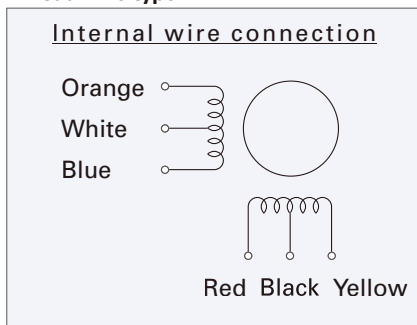

## Bipolar winding

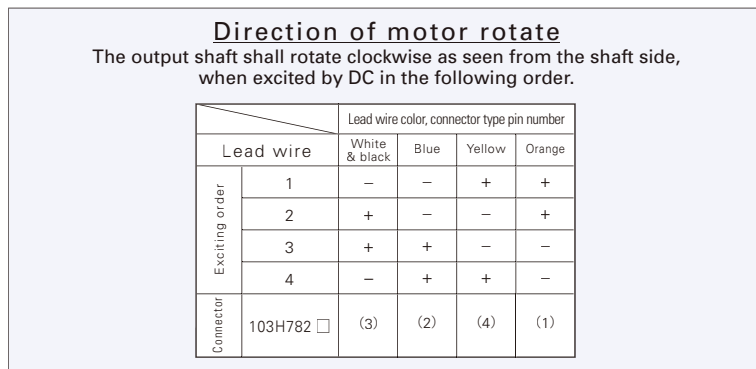
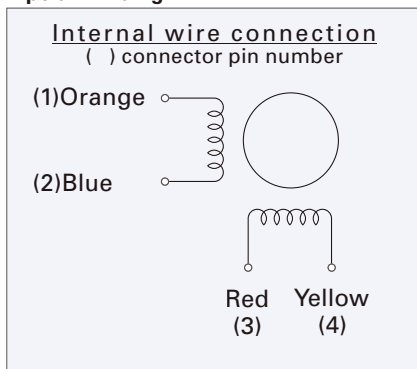



### 50mm (1.97inch)

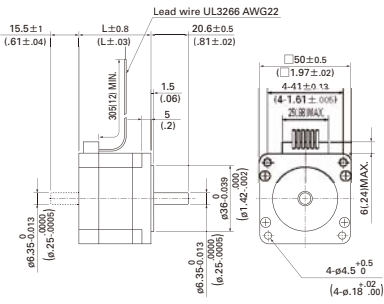

Lead wire type

	Set part number	Motor model number	Motor length : mm (inch)	Cable type
Unipolar	—	103H6701-01 △ 0	39.8 (1.57)	Lead wire
	—	103H6701-04 △ 0	39.8 (1.57)	Lead wire
	—	103H6701-07 △ 0	39.8 (1.57)	Lead wire
	—	103H6703-01 △ 0	51.3 (2.02)	Lead wire
	—	103H6703-04 △ 0	51.3 (2.02)	Lead wire
	—	103H6703-07 △ 0	51.3 (2.02)	Lead wire
	—	103H6704-01 △ 0	55.8 (2.20)	Lead wire
	—	103H6704-04 △ 0	55.8 (2.20)	Lead wire
Bipolar	DB16H671 ▽	103H6701-50 △ 0	39.8 (1.57)	Lead wire
	DB16H672 ▽	103H6703-50 △ 0	51.3 (2.02)	Lead wire
	—	103H6704-50 △ 0	55.8 (2.20)	Lead wire

### 56mm (2.20inch)

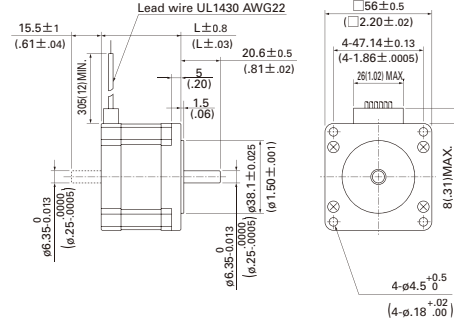

Lead wire type

	Set part number	Motor model number	Motor length : mm (inch)	Cable type
Unipolar	DU16H711 △	103H7121-04 △ 0	41.8 (1.65)	Lead wire
	DU16H713 △	103H7123-04 △ 0	53.8 (2.12)	Lead wire
	DU16H716 △	103H7126-04 △ 0	75.8 (2.98)	Lead wire
	—	103H7121-01 △ 0	41.8 (1.65)	Lead wire
	—	103H7121-07 △ 0	41.8 (1.65)	Lead wire
	—	103H7123-01 △ 0	53.8 (2.12)	Lead wire
	—	103H7123-07 △ 0	53.8 (2.12)	Lead wire
	—	103H7124-01 △ 0	63.8 (2.51)	Lead wire
	—	103H7124-04 △ 0	63.8 (2.51)	Lead wire
	—	103H7124-07 △ 0	63.8 (2.51)	Lead wire
	—	103H7126-01 △ 0	75.8 (2.98)	Lead wire
	—	103H7126-04 △ 0	75.8 (2.98)	Lead wire
	—	103H7126-07 △ 0	75.8 (2.98)	Lead wire

### 56mm (2.20inch)

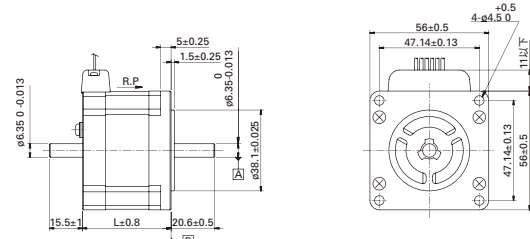

Lead wire type

	Set part number	Motor model number	Motor length : mm (inch)	Cable type
Unipolar	—	103H7121-61 △ 0	41.8 (1.65)	Lead wire (CE)
	—	103H7121-67 △ 0	41.8 (1.65)	Lead wire (CE)
	—	103H7123-61 △ 0	53.8 (2.12)	Lead wire (CE)
	—	103H7123-67 △ 0	53.8 (2.12)	Lead wire (CE)
	—	103H7126-61 △ 0	75.8 (2.98)	Lead wire (CE)
	—	103H7126-67 △ 0	75.8 (2.98)	Lead wire (CE)

### 56mm (2.20inch)

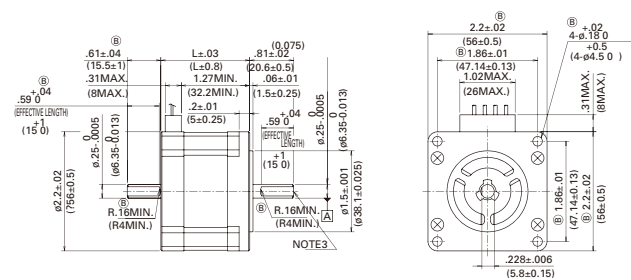

Lead wire type

	Set part number	Motor model number	Motor length : mm (inch)	Cable type
Bipolar	DB16H711 △	103H7121-57 △ 0	41.8 (1.65)	Lead wire
	DB16H713 △	103H7123-57 △ 0	53.8 (2.12)	Lead wire
	DB16H716 △	103H7126-57 △ 0	75.8 (2.98)	Lead wire
	—	103H7121-56 △ 0	41.8 (1.65)	Lead wire
	—	103H7121-58 △ 0	41.8 (1.65)	Lead wire
	—	103H7123-56 △ 0	53.8 (2.12)	Lead wire
	—	103H7123-58 △ 0	53.8 (2.12)	Lead wire
	—	103H7126-56 △ 0	75.8 (2.98)	Lead wire
	—	103H7126-58 △ 0	75.8 (2.98)	Lead wire
	—	103H7128-56 △ 0	94.8 (3.73)	Lead wire
	—	103H7128-57 △ 0	94.8 (3.73)	Lead wire
	—	103H7128-58 △ 0	94.8 (3.73)	Lead wire

### 60mm (2.36inch)

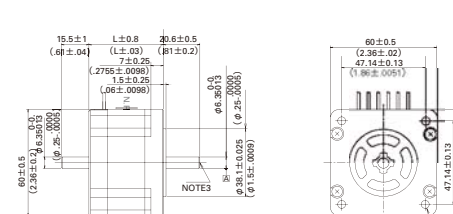

Lead wire type

	Set part number	Motor model number	Motor length : mm (inch)	Cable type
Unipolar	—	SH1601-04 △ 0	44.8 (1.76)	Lead wire
	—	SH1602-04 △ 0	53.8 (2.12)	Lead wire
	—	SH1603-04 △ 0	85.8 (3.38)	Lead wire
Bipolar	DB16S161 △	SH1601-52 △ 0	44.8 (1.76)	Lead wire
	DB16S162 △	SH1602-52 △ 0	53.8 (2.12)	Lead wire
	DB16S163 △	SH1603-52 △ 0	85.8 (2.12)	Lead wire

Model number	Shaft diameter	Disc thickness
103H7121-□□□□	φ 6.35	5.8
103H7123-□□□□		
103H7126-□□□□		
103H7128-□□□□	φ 8	7.5

Model number	Shaft diameter	Disc thickness
SH1601-□□□□	φ 6.35	5.8
SH1602-□□□□		
SH1603-□□□□		
	φ 8	7.5

#### △ : Motor shaft specification code

Motor shaft spec	Set type code	Motor type code
Single shaft	S	4
Double shafts	D	1

#### ▽ : Motor shaft specification code

Motor shaft spec	Set type code	Motor type code
Single shaft	S	7
Double shafts	D	3



## Safety Consideration

The drivers and stepping motors are the products designed to be used for the general industrial devices.

When using those, pay enough attention to the following points.

- Read thoroughly the Operation Manual prior to placement, assembly and/or operation in order to use the product properly.
- Refrain from modifying or processing the product in any way.
- Consult with the distributor or professional experts for placement or maintenance services of the product.
- In case of the following uses of the product, contact with us for the special care required to the operation, maintenance and management such as multiplexing the system, installing an emergency electric generator set, or so forth.

- 1 Use for the medical devices concerned with a fatal accident.
- 2 Use for trains, elevators, and so forth that are likely to cause an accident resulting in injury, damage or death.
- 3 Use in the computer system highly influential to the social life or the public systems.
- 4 Use in other devices highly influential to maintaining the human safety or the public functions.

In addition to the above, consult with us for use in such a vibration environment as automobile or transportation.

Read the Operation Manual thoroughly prior to the use (placement, operation, maintenance and inspection) to put the product in use properly.

Make yourself knowledgeable and familiarize with the devices, safety issues and cautions before handling the product.

After reading the Operation Manual or the like, keep it in the place where the users can refer to whenever necessary.

## Indication by (Warning Label) on the product

Either or all of the following indications are given by the Warning Labels depending on the type of the driver or stepping motor.



This label is stuck near the high voltage part such as the electrically charged or cover-protected section, warning that the place where it is likely to cause an electric shock.



This label is stuck on the place where the driver or stepping motor body should be easily acknowledged, warning that it is likely to cause burns from high temperature.



必ずアース線を  
接続してください  
Use proper  
grounding  
techniques.

This label is stuck near the GND terminals of the driver or stepping motor for which grounding is required, suggesting that the terminals should be actually grounded.



危険  
WARNING  
感電注意  
May Cause  
electric shock

This label is stuck for the driver or stepping motor to which the power source is applied in the voltage exceeding the safety standard, drawing attention against the electric shock.

## Safety ranks of the cautions

Following four ranks are provided.



**DANGER** Improper operations or use is most likely to result in serious injury or death.



**CAUTION** Improper operations or use is likely to result in average or minor injury, or in property damage.

In spite of the cautions with the  $\triangle$  CAUTION label, it may cause serious results. Either the contents of the labels is describing important cautions to be followed inevitably.



**PROHIBITED** Indicates what shall not be done.



**COMPULSORY** Indicates what shall be done.

## DANGER

### < General matters >

1. Do not use the product in an explosive, flammable or corrosive atmosphere, watery place or near a combustible material. Doing so may cause injury or fire.
2. Have a person with expert knowledge for performing the transportation, placement, wiring, operation, maintenance or inspection of the product. Without such knowledge, it may cause an electric shock, injury or fire.
3. Do not work for wiring, maintenance servicing or inspection with the electric power on. Perform either of those five minutes after turning the power off, or otherwise, it may cause an electric shock.
4. When the protective functions of the product is activated, turn the power off immediately and eliminate the cause. If continuing the operation without eliminating the cause, the product may operate improperly and cause injury or a breakdown of the system devices.
5. Stepping motor may run out of order at the operating and stopping occasions, depending on the magnitude of the load. Put the product into use after confirming with the adequate trial test operation in the maximum load conditions that the product performs reliable operation. Doing otherwise may cause a breakdown of the system. (Should the product run out of order in the use to drive upward/downward, it may cause a fall of the load.)
6. Do not touch the internal parts of the driver. Doing so may cause an electric shock.

### < Wiring >

7. Do not connect the stepping motor directly with the commercial power outlet. Doing so may cause an electric shock, injury or fire. The power shall be supplied to the stepping motor through the driving circuit.
8. Use the electric power source within the rated input voltage. Using otherwise may cause fire or an electric shock.
9. Connect the driver and stepping motor to the ground. Using without grounding may cause an electric shock.
10. Do not harm, forcibly put a stress, or load a heavy article on the cable or get it caught between the articles. Doing so may cause an electric shock.
11. Perform wiring with the power cable as instructed by the wiring diagram or the Operation Manual. Doing otherwise may cause an electric shock or fire.

### < Operation >

12. Be sure not to touch the rotating part of the stepping motor during its operation. Touching it may cause injury.
13. Neither reach or touch the electric terminals while electric power is on. Doing so may cause an electric shock.
14. Never disconnect any of the connectors while electric power is on. Doing so may cause an electric shock and corruption.

### < General matters >

1. Prior to placement, operation, maintenance servicing or inspection, be sure to read the Operation Manual and follow the instructions to perform those. Failure to follow the instructions may cause an electric shock, injury or fire.
2. Do not use the driver or the stepping motor outside the specified conditions. Doing so may cause an electric shock, injury or fire.
3. Do not insert a finger or a thing into the opening of the product. Doing so may cause an electric shock, injury or fire.
4. Do not use the damaged driver or stepping motor. Doing so may cause injury, fire or the like.
5. Use the driver and stepping motor in the designated combination. Using otherwise may cause fire or a trouble.
6. Be careful that the temperature rises in the operating driver, stepping motor or peripheral devices. Failure to be careful may cause a burn.

### < Unpacking >

7. Unpack while confirming the ceiling. Failure to do so may cause injury.
8. Confirm if the product is the one having been ordered. Installing an incorrect product may cause a breakdown.

### < Wiring >

9. Do not perform measurement of the insulation resistance or withstand insulation voltage of the product. Doing so may cause a breakdown. Instead, contact with us for such inspection.
10. Perform wiring conforming to the technical standards of electric facility or the internal rule. Doing otherwise may cause burning or fire.
11. Ensure that wiring has been correctly done. Operating without correct wiring may cause the stepping motor to run out of control and result in injury.

12. Take insulation process for the attached condenser or the external resistance connection terminals. Failure to do so may cause an electric shock.

### < Placement >

13. Do not climb or attach a heavy article on the product. Doing so may cause injury.
14. Neither block nor stuff the aspiration/exhaust vent with a foreign particle. Doing so may cause fire.
15. Follow the instructions for the direction to place. Failure to do so may cause a trouble.
16. Keep a distance as instructed by the Operation Manual for the driver from the inner surface of the control console or other devices. Failure to do so may cause a trouble.
17. Place the product with a great care so as to prevent from the danger such as a tumble or a turnover.

## CAUTION

18. Mount the product on an incombustible material such as metal. Doing otherwise may cause fire.
19. Confirm the rotating direction before connecting with the mechanical device. Failure to do so may cause injury or a breakdown.
20. Do not touch the motor output spindle (including the key slot and gears) with a bare hand. Doing so may cause injury.

### < Operation >

21. The stepping motor is not equipped with any protective device. Take protective measures using an over-current protective relay, a ground fault interrupter, a protective device from excess temperature, and an emergency stopping device. Failure to do so may cause injury or fire.
22. Do not touch the product for a period after the power is on or has been turned off, since the driver and stepping motor remain in the high temperature. Doing so may cause burns. Especially the temperature rises considerably of the stepping motor depending on the operating conditions. Use the motor on the condition so that its surface temperature becomes 100°C or under.
23. Stop the operation immediately when an emergency occurs. Failure to do so may cause an electric shock, injury or fire.
24. Do not change adjustment to an extreme, for such a change results in the unstable operation. Doing so may cause injury.
25. When conducting the trial operation, make the stepping motor fixed firmly, and confirm the operation by disconnecting with the mechanical system before connecting with it. Failure to do so may cause injury.
26. When the alarm has been activated, eliminate the cause and ensure the safety to resume operation. Failure to do so may cause injury.
27. When the electric power recovers after the momentary interruption, do not approach the devices because the system may re-start operation by itself. (Set the system so as to secure the safety even when it re-start on such occasion.) Failure to do so may cause injury.
28. Confirm that the electric power supply is all proper conforming to the specifications. Failure to do so may cause a trouble.
29. The brake mechanism of the motor with the electro-magnetic brake is to hold the movable section and the motor position. Do not use it as a safety measure, or doing so may cause the breakdown of the system.
30. Fix the key firmly when operating the motor with key individually. Failure to do so may cause injury.

### < Maintenance services >

31. Be careful when performing maintenance services or inspection about the temperature which rises highly in the driver and stepping motor frame. Failure to do so may cause burns.
32. It is recommended to replace the electrolytic condenser of the driver with a new one for securing the preventive measure after using for 5 years, the expected life in the average 40°C. The expected life of the fuse is 10 years in the average 40°C. Thus, the periodical replacement is recommended.

33. Contact with us for repair. If the product is disassembled by the user, it may put it out of action.

### < Transportation >

34. Handle the product with care during transportation so as to prevent from the danger such as a tumble or a turnover.
35. Do not hold with the cable or the motor spindle. Doing so may cause a trouble or injury.

### < Retirement >

36. When scrapping the driver or stepping motor, treat it for the general industrial waste.

## PROHIBITED

### < Storage >

1. Avoid the place exposed to rain or water drops, or in an environment with hazardous gas or liquid for storing the product. Failure to do so may cause a trouble.

### < Maintenance services >

2. Do not assemble or repair the product. Doing so may cause fire or an electric shock.

### < General matters >

3. Do not remove the rating plate.

## COMPULSORY

### < Storage >

1. Store the product within the specified conservation temperature and humidity in the place not exposed to the sun beam.

2. If the driver has been stored for a long period (3 years or longer for a guide), consult with us. The capacitance may have decreased with the electrolytic condenser due to the long period storage, and it may cause a trouble.

### < Operation >

3. Install an external emergency stop circuit to turn the power off for the instant halt of operation.
4. Put the product into operation in the specified ambient temperature and humidity.

### < Transportation >

5. Excess loading of the product on the carrier may cause the load to fall in pieces. Follow the instructions given outside the package.

# Inquiry Check Sheet

Please provide the following information when placing an order or making an inquiry.  
Also feel free to include any questions that require our attention.

Company Name: \_\_\_\_\_

Date: \_\_\_\_\_

Department: \_\_\_\_\_

To contact us: \_\_\_\_\_

Telephone : \_\_\_\_\_

Phone: +81 3 3917 5157

Fax: \_\_\_\_\_

Fax: +81 3 3917 0643

1) Application: \_\_\_\_\_

2) Name of Machinery: \_\_\_\_\_

3) Number of Units: \_\_\_\_\_

Item	Contents																																																																																																
①	Name of target equipment Equipment name, category (transport, processing, test, other)																																																																																																
②	Name of servo axis Axis name, axial mechanism (horizontal/vertical), brake mechanism (yes/no)																																																																																																
③	Current condition of above axis Manufacturer Name ( ) Series Name ( ) Motor Capacity ( ) Hydraulic, Mechanical, or New System ( )																																																																																																
④	Positioning accuracy ± mm / ± μm																																																																																																
⑤	Operation pattern <p>Reference formula:  <math>[1G=9.8, m/s^2], 1(m/s^2) \approx 0.1G]</math>  <math>[\alpha(m/s^2)=V(m/sec) \div t1(sec)]</math>  <math>[D(m)=V(m/sec) \times (t1+t2)(sec)]</math></p>																																																																																																
⑥	Mechanism Ball-screw/screw-rotation type (horizontal), ball-screw/nut-rotation type (horizontal), rack and pinion (horizontal), belt/chain (horizontal), rotary table, roll feed, instability																																																																																																
⑦	Mechanical structure <table border="0"> <tr> <td>WT (table mass)</td> <td>kg</td> <td>WL (work mass)</td> <td>kg</td> <td>WA (mass of other drive parts)</td> <td>kg</td> </tr> <tr> <td>WR (rack mass)</td> <td>kg</td> <td>WB (belt/chain mass)</td> <td>kg</td> <td>WC (counterbalance mass)</td> <td>kg</td> </tr> <tr> <td>Fa (external force in axial direction)</td> <td>N</td> <td>Fb (ball-screw preload)</td> <td>N</td> <td>T (roll pushing force)</td> <td>N</td> </tr> <tr> <td>Dr1 (drive-side roll diameter)</td> <td>mm</td> <td>Dr2 (follower-side roll diameter)</td> <td>mm</td> <td></td> <td></td> </tr> <tr> <td>Lr1 (drive-side roll length)</td> <td>mm</td> <td>Lr2 (follower-side roll length)</td> <td>mm</td> <td>G (reduction ratio)</td> <td></td> </tr> <tr> <td>JG (speed-reducer inertia)</td> <td>kg·m<sup>2</sup></td> <td>JC (coupling inertia)</td> <td>kg·m<sup>2</sup></td> <td></td> <td></td> </tr> <tr> <td>JN (nut inertia)</td> <td>kg·m<sup>2</sup></td> <td>JO (other motor-axis conversion inertia)</td> <td>kg·m<sup>2</sup></td> <td></td> <td></td> </tr> <tr> <td>Db (ball-screw diameter)</td> <td>mm</td> <td>Lb (ball-screw axial length)</td> <td>mm</td> <td>Pb (ball-screw lead)</td> <td>mm</td> </tr> <tr> <td>Dp (pinion/pulley diameter)</td> <td>mm</td> <td>Lp (pinion axial length)</td> <td>mm</td> <td>Tp (pulley thickness)</td> <td>mm</td> </tr> <tr> <td>Dt (table diameter)</td> <td>mm</td> <td>Dh (table-support diameter)</td> <td>mm</td> <td>LW (load shift from axis)</td> <td>mm</td> </tr> <tr> <td>Ds (table shaft diameter)</td> <td>mm</td> <td>Ls (table shaft length)</td> <td>mm</td> <td></td> <td></td> </tr> <tr> <td>ρ (specific gravity of ball-screw/pinion/pulley/table-shaft material)</td> <td></td> <td></td> <td>kg/cm<sup>3</sup></td> <td></td> <td></td> </tr> <tr> <td>μ (friction coefficient between sheet and sliding-surface/support-section/roll)</td> <td></td> <td>P1 (specific gravity of roll-1 material)</td> <td></td> <td></td> <td>kg/cm<sup>3</sup></td> </tr> <tr> <td>ρ2 (specific gravity of roll-2 material)</td> <td></td> <td>κ (internal friction coefficient of preload nut)</td> <td></td> <td></td> <td></td> </tr> <tr> <td>η (mechanical efficiency)</td> <td></td> <td>JL (load inertia of motor-axis conversion)</td> <td></td> <td></td> <td>kg·m<sup>2</sup></td> </tr> <tr> <td>TF (friction torque of motor axis conversion)</td> <td></td> <td>TU (imbalance torque of motor axis conversion)</td> <td></td> <td></td> <td>N·m</td> </tr> </table>	WT (table mass)	kg	WL (work mass)	kg	WA (mass of other drive parts)	kg	WR (rack mass)	kg	WB (belt/chain mass)	kg	WC (counterbalance mass)	kg	Fa (external force in axial direction)	N	Fb (ball-screw preload)	N	T (roll pushing force)	N	Dr1 (drive-side roll diameter)	mm	Dr2 (follower-side roll diameter)	mm			Lr1 (drive-side roll length)	mm	Lr2 (follower-side roll length)	mm	G (reduction ratio)		JG (speed-reducer inertia)	kg·m <sup>2</sup>	JC (coupling inertia)	kg·m <sup>2</sup>			JN (nut inertia)	kg·m <sup>2</sup>	JO (other motor-axis conversion inertia)	kg·m <sup>2</sup>			Db (ball-screw diameter)	mm	Lb (ball-screw axial length)	mm	Pb (ball-screw lead)	mm	Dp (pinion/pulley diameter)	mm	Lp (pinion axial length)	mm	Tp (pulley thickness)	mm	Dt (table diameter)	mm	Dh (table-support diameter)	mm	LW (load shift from axis)	mm	Ds (table shaft diameter)	mm	Ls (table shaft length)	mm			ρ (specific gravity of ball-screw/pinion/pulley/table-shaft material)			kg/cm <sup>3</sup>			μ (friction coefficient between sheet and sliding-surface/support-section/roll)		P1 (specific gravity of roll-1 material)			kg/cm <sup>3</sup>	ρ2 (specific gravity of roll-2 material)		κ (internal friction coefficient of preload nut)				η (mechanical efficiency)		JL (load inertia of motor-axis conversion)			kg·m <sup>2</sup>	TF (friction torque of motor axis conversion)		TU (imbalance torque of motor axis conversion)			N·m
WT (table mass)	kg	WL (work mass)	kg	WA (mass of other drive parts)	kg																																																																																												
WR (rack mass)	kg	WB (belt/chain mass)	kg	WC (counterbalance mass)	kg																																																																																												
Fa (external force in axial direction)	N	Fb (ball-screw preload)	N	T (roll pushing force)	N																																																																																												
Dr1 (drive-side roll diameter)	mm	Dr2 (follower-side roll diameter)	mm																																																																																														
Lr1 (drive-side roll length)	mm	Lr2 (follower-side roll length)	mm	G (reduction ratio)																																																																																													
JG (speed-reducer inertia)	kg·m <sup>2</sup>	JC (coupling inertia)	kg·m <sup>2</sup>																																																																																														
JN (nut inertia)	kg·m <sup>2</sup>	JO (other motor-axis conversion inertia)	kg·m <sup>2</sup>																																																																																														
Db (ball-screw diameter)	mm	Lb (ball-screw axial length)	mm	Pb (ball-screw lead)	mm																																																																																												
Dp (pinion/pulley diameter)	mm	Lp (pinion axial length)	mm	Tp (pulley thickness)	mm																																																																																												
Dt (table diameter)	mm	Dh (table-support diameter)	mm	LW (load shift from axis)	mm																																																																																												
Ds (table shaft diameter)	mm	Ls (table shaft length)	mm																																																																																														
ρ (specific gravity of ball-screw/pinion/pulley/table-shaft material)			kg/cm <sup>3</sup>																																																																																														
μ (friction coefficient between sheet and sliding-surface/support-section/roll)		P1 (specific gravity of roll-1 material)			kg/cm <sup>3</sup>																																																																																												
ρ2 (specific gravity of roll-2 material)		κ (internal friction coefficient of preload nut)																																																																																															
η (mechanical efficiency)		JL (load inertia of motor-axis conversion)			kg·m <sup>2</sup>																																																																																												
TF (friction torque of motor axis conversion)		TU (imbalance torque of motor axis conversion)			N·m																																																																																												
⑧	Speed reducer Customer-provided ( / ); Sanyo standard (planet/spur/no-backlash-planet:: / ); other ( / )																																																																																																
⑨	Sensor type Sensor type specified ( yes / no ) Yes: ( incremental , optical absolute , optical absolute [resolver absolute with incremental function] ) Resolution ( )																																																																																																
⑩	Input format Position , speed, torque, communications ( SERCOS / CAN / DeviceNet ) other ( )																																																																																																
⑪	Upper-level equipment (controller) Sequencer , laptop , customer-developed product , Sanyo-provided , other ( )																																																																																																
⑫	Usage environment and other requirements Cutting , clean-room use , anti-dust measures , other ( )																																																																																																
⑬	Estimated production Single product: ( ) units/month ( ) units/year																																																																																																
⑭	Development schedule Prototype period: ( )Year ( )Month Production period: ( )Year ( )Month																																																																																																
⑮	Various measures Related documentation ( already submitted ; send later by mail ) Visit/PR desired ( yes / no ) Meeting desired ( yes / no )																																																																																																
⑯	Miscellaneous (questions, pending problems, unresolved issues, etc.)																																																																																																