

Multi Position Cylinder MPC

If your application needs more than two positions, higher dynamics & longer life...

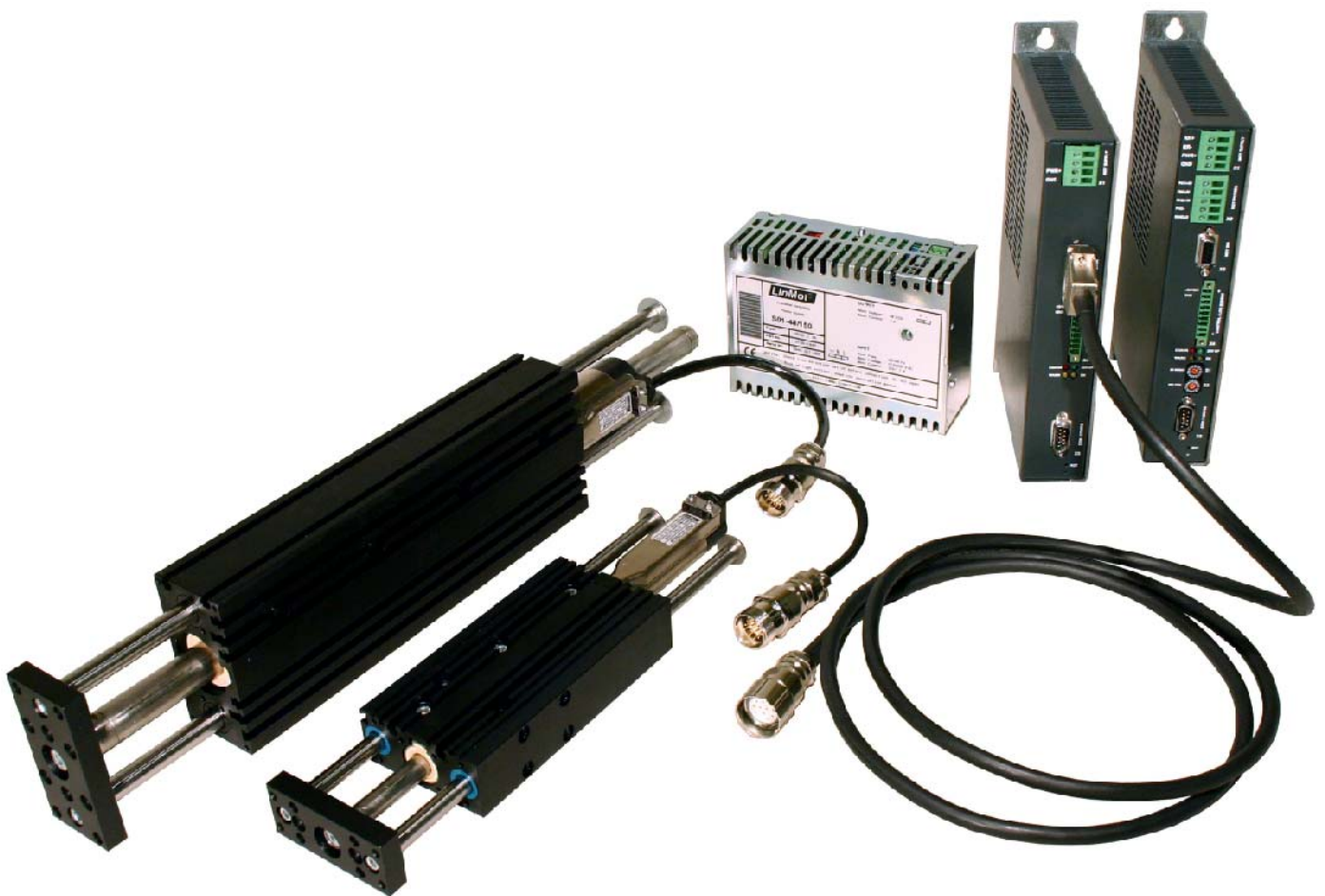

- Multi position
- High dynamics
- Adjustable force
- No air required
- No wearing parts
- Simple configuration

The MPC System



Multi Position Cylinder are easy to use electronic positioning units. The MPC system has been specially developed for high dynamic applications and for positioning tasks that requires more than two positions.

Multi Position Cylinders are used in:

- Packaging machines
- Assembly lines
- Pick and place
- Production lines
- Textile machines
- etc.

Servo Controller

The Servo Controller are single axes position control units. The multiple programmable set positions are stored in the controller. By activating one of the digital inputs, the move to reach the corresponding set position will be started. As soon as the Linear Module reaches the set position, the corresponding "InPosition" output will be activated.

The Servo Controller may store up to 256 positions or commands in a table. This command table is generated on a PC or Laptop with the MPC Software and downloaded to the controller via the serial RS232 interface.

For fieldbus connectivity, Servo Controllers with Profibus, DeviceNet and CanOpen are available.

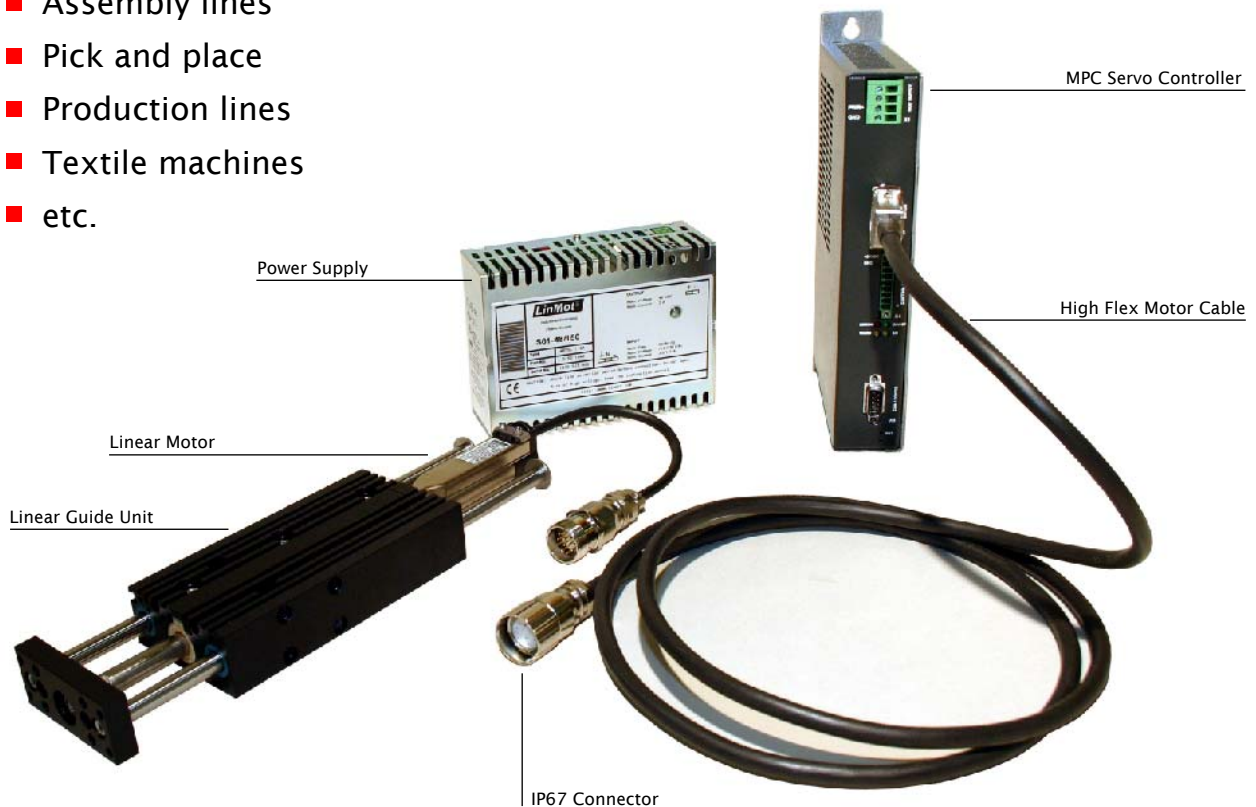

Linear Motor

The Linear Modules are driven by an industrial Linear Motor. As the linear motor generates the linear movements directly and without air, there are no mechanical components like gears, seals or dampers. This provides long life even in applications with high dynamic movements and very short cycle times.

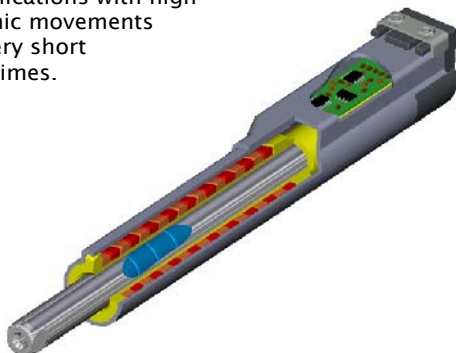

The Linear Motor consists of only two parts; the Slider with the motor magnets, and the Stator with motor coils and intergrated position and temperature sensors.

Linear Guide Unit

The linear guide units are reliable, high precision guiding systems with linear ball bearings. The guide unit protects the linear motor against side forces and eliminates rotation of the slider. It permits direct mounting of payloads without any additional mechanical elements. Dimensions and mounting possibilities are 100% compatible with pneumatic H-Guides.

Motor Cable & Connector

The Multi Position Cylinder requires only one cable between Servo Controller and Linear Motor. This reduces installation time and commissioning cost to a minimum. Using the MPC extension cable, the motor cable may reach a maximum length of 50m (165ft).

Power Supply

The Multi Position Cylinders are powered from a AC/DC power supply (input switch 115/230VAC). The 72VDC power supplies are used in applications with high dynamic movements. For less demanding positioning tasks, the 48VDC supplies are sufficient.

Multi-Functional

The MPC's high flexibility guarantees simple solutions and fast implementation even for high dynamic or complex positioning tasks.

Free positioning

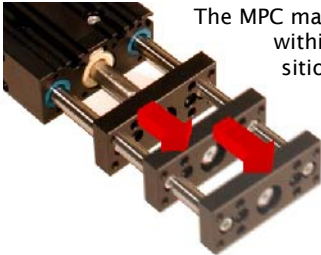

The MPC may be positioned to any position within the its stroke range. The positions are controlled electronically without any mechanical end-stops.

Position repeatability is 0.1mm (0.004inch).

High Dynamic Response

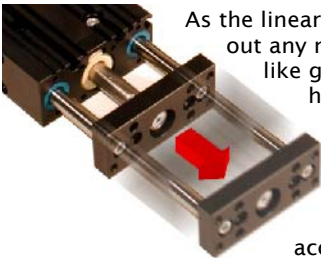

As the linear movement is generated without any mechanical force transmission like gearing, belts or spindels, very high dynamics may be reached without any negative impact on life time.

Slow and gentle movements may be executed according to the applications need by reducing the motion time.

Configurable Press Force

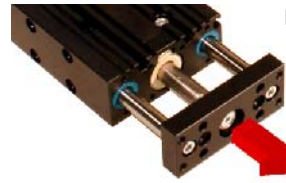

For assembling tasks, the force of the MPC may be programmed as required. A set position is reached with a limited force. As soon as the MPC presses with the programmed force, the corresponding output is activated. The output remains active, as long as the programmed force is applied.

Teach Mode



The set positions may be taught moving the MPC in the stepping mode to the desired position. In order to simplify the teach procedure, the MPC may also be moved by hand to the desired set position.

Mechanically Compatible



Dimensions and mounting possibilities of the Linear Guide Units are 100% compatible to the mechanical dimensions of H-Guides for pneumatic cylinders.

Simple: Configuration & Start-up

As there are no time consuming mechanical adjustment with the MPC, start-up is very fast and simple. The entire configuration is limited to select the module type, enter the set positions, speed and payload.

The MPC Configurator is a MS Windows based program for module configuration and programming of the set positions. Configuration is limited to the selection of the module type. Position controller setup and minimal positioning times for each movement will be calculated automatically. This assures that all the set positions will be reached in the minimal time with optimized settings for each move. Warnings and Errors will be shown in clear text messages in one of several different languages.

Command Name	Action	Function	Distance / Inca	Extra Payload	Speed	Press Force
Cmd1	Go	Absolute Move	0 mm	g	10 %	
Cmd2	Go	Absolute Move	5 mm	g	10 %	
Cmd3	Go	Absolute Move	20 mm	g	25 %	
Cmd4	Go	Absolute Move	50 mm	g	50 %	
Cmd5	Go	Relative Move	0 mm	g	100 %	
Cmd6	Go	Relative Move	-10 mm	g	100 %	
Cmd7	Go	Press	00 mm			35 N
Cmd8	Go	Press	50 mm			20 N

The following commands are available:

Absolute Move

On an absolute move, the Multi Position Cylinder moves to the programmed position at a configurable speed. The speed is entered in % of the minimal positioning time the module may achieve with the actual payload. Absolute Positions may be taught.

Relative Move

The relative move is a displacement from the actual position by the programmed distance. With the relative move, programming of stacker applications, for example is very simple.

Press with limited force

With the press command, the MPC moves to a set position with a programmable force. A digital output is activated as soon as the MPC produces the programmed force.

The MPC Controller E1100



The MPC Controllers are compact servo controllers with integrated power stages for precise control and fast positioning of the Linear Modules.

The MPC's powerful microprocessor system assures fast and precise positioning. On a transaction of the input signal, the corresponding command stored in the controller is executed without a delay.

The Motor's integrated position sensors permits the MPC controller to monitor end positions without additional limit switches. Not only positions but the whole motion profile between end positions is monitored. This makes it possible to monitor positioning times in order to guarantee process stability over the entire life.

Interfaces

1. Motor Supply
2. Motor Connector
3. Control Signals & Logic Supply
4. LED State Display
5. Address Switch for field bus Interfaces
6. Serial Interface RS232
7. Positions In- & Outputs

Motor phases on High Current Controller (-HC) must be connected on the screw terminals above the motor connector (2).

For integration in field bus systems, Servo Controllers with Profibus, DeviceNet und CanOpen interfaces are available.

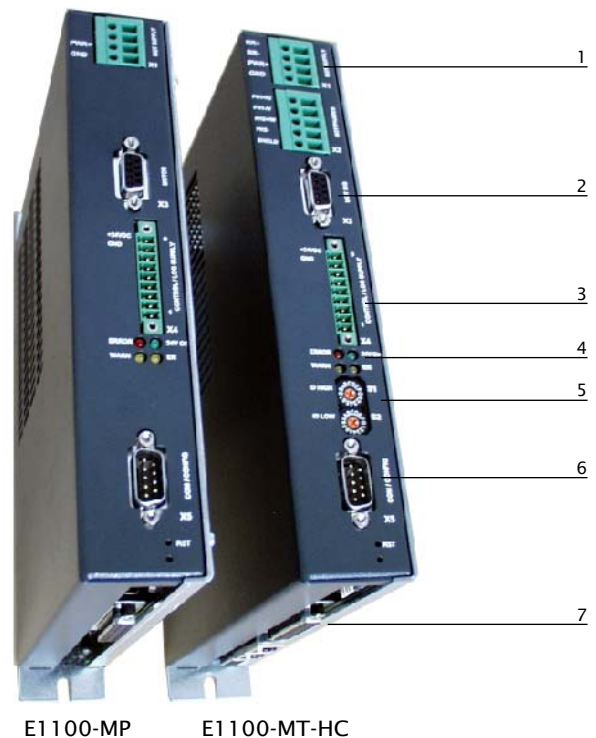

Inputs

The MPC system is started with the control inputs "Enable" and "Home". During operation the positions stored in the command table may be called by activating the inputs "Position 1-8". The 8 inputs of the E1100-MP corresponds to the 8 positions/commands. The E1100-MT's 256 positions/commands are addressed with the 8 inputs.

If the "/Stop" input is turned off, the controller will decelerate to zero velocity, then linear motor is turned off. This guarantees that the motor will not run into the mechanical stop, if motor power is turned off for E-Stop.

Outputs

As soon as the Linear Module reaches the set position, the common "In Position" output and the command specific "In Position 1-8" output are activated. The output "/Warning" may be used for module diagnostics. This output indicates that the module still works, but the mechanics should be controlled in order to assure problem free operation.

The "/Error" output is active if the drive is in the error state (motor is not working). A mechanical brake or clamping unit may be directly controlled by the "/Brake" output. This output is always active, if the motor is off.

Supply

The MPC Controllers E1100 have two separate supply inputs for power and logic. On an emergency stop on the machine, only the motor supply has to be turned off. This assures that set and actual position and also the last commands remain stored in the controller.

Inputs:

- Enable
- Home
- /Stop

Outputs:

- /Warning
- /Error
- /Brake
- In Position

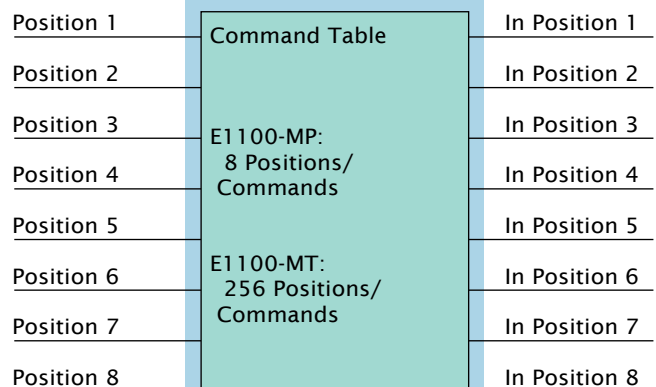

- Logic Supply
- Motor Supply

The MPC Linear Module LM01



1. Front plate
with centering holes for fast and precise payload mounting
2. Hardened Shafts
for accurate linear feed motion and minimal noise
3. Precision Bearings
Recirculating ball bearings for high payloads and long life
4. Guide Block
with centering holes for fast and precise mounting of the linear module
5. Mechanical endstop (backend)
6. Linear Motor Stator (IP67)
with integrated motor coils and sensors for position feedback and over temperature protection
7. Screws and clamping cylinder to fix the linear motor in the guide block
8. Mounting nuts in the guide block for fast mounting of accessories
9. Linear Motor Slider
for precise positioning and maximal force generation
10. Backlash free linear coupling
guarantees fast and parallel mounting for the slider

Modularity & Accessories

The Linear Modules may be extended with optional features. This modularity provides maximal flexibility and permits optimal adaptation for a large range of applications.

Optional MagSpring

In vertical applications the magnetic spring MagSpring may be used to compensate the gravity force of the payload or to prevent the Multi Position Cylinder from falling to the lower end stop if the power is turned off.

Optional Mechanical Brake

The linear guide units series LM01-37 have mounting holes for pneumatic clamping units. These units automatically lock the MPC upon interruption of electrical or air supply. The valve for the clamping unit may be directly controlled from the Controller's digital /BRAKE output.

Optional Fan

Using a fan for cooling will almost double the continuous force of the Multi Position Cylinder. A 24VDC fan may be directly mounted on the linear guide unit. The fan comes as a complete set with all the mounting parts. The module height with a fan increases by about 40mm (1.6 in).

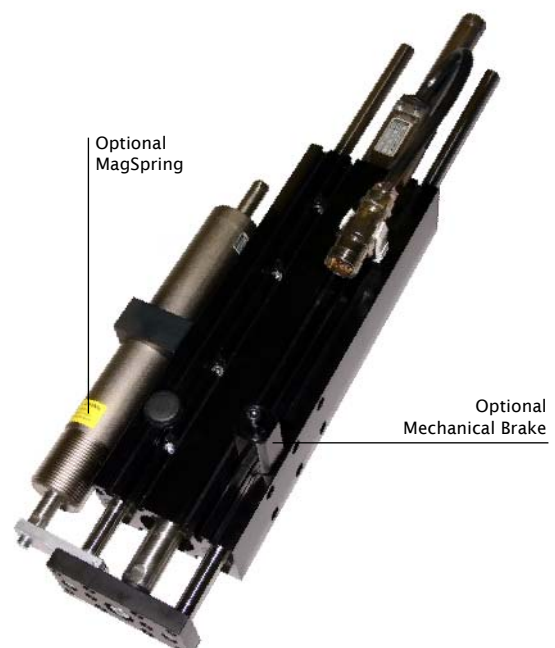

More Speed for your application



Positioning time LM01-23x80

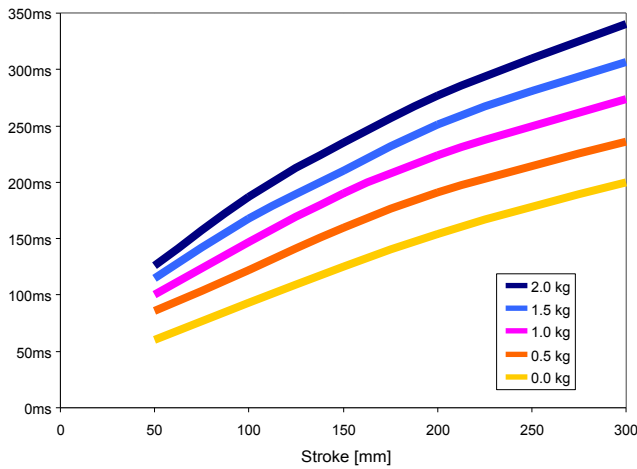

Positioning time LM01-23x160

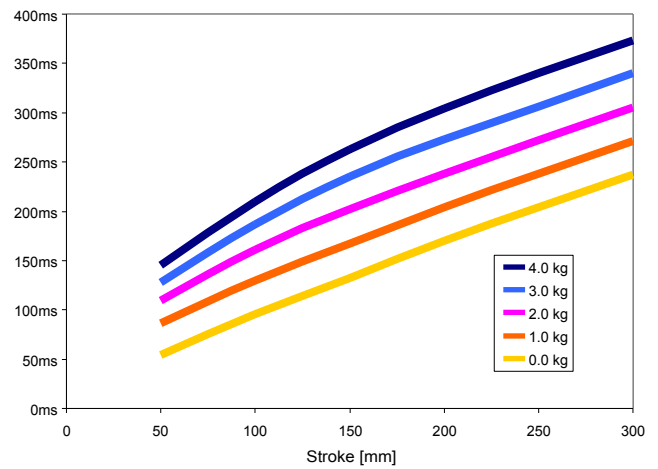

Positioning time LM01-37x120

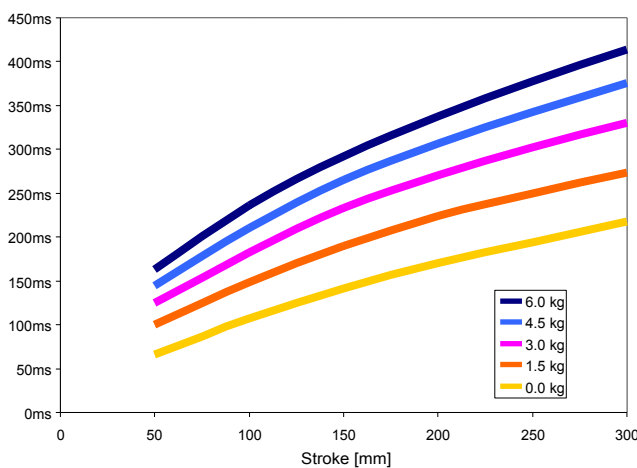

Positioning time LM01-37x240

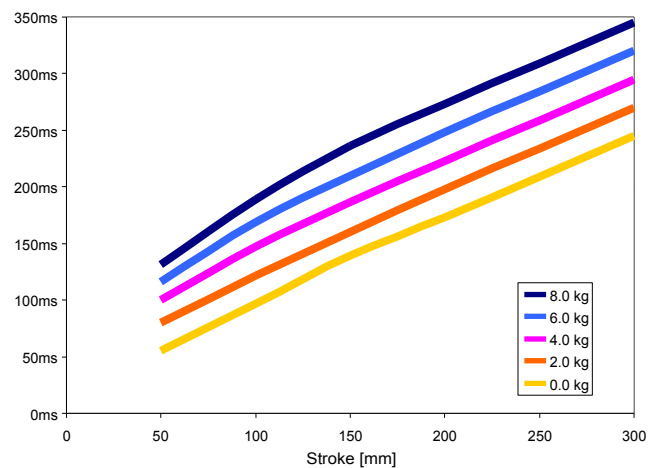

The diagrams show the minimal positioning time for a horizontal point to point movement using a 72VDC power supply.

Using a 48VDC power supply, above positioning times will increase by at least 50%.

Max. Payload

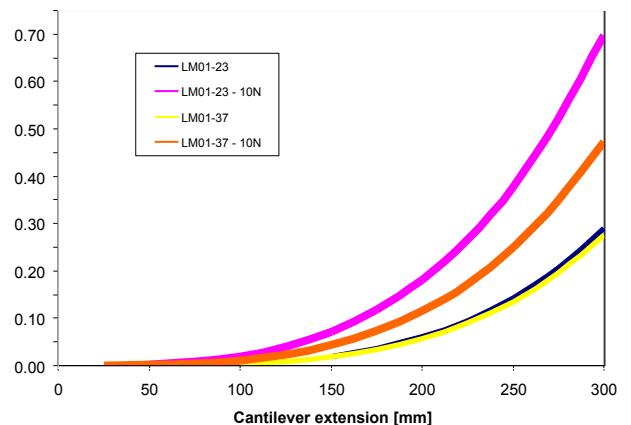
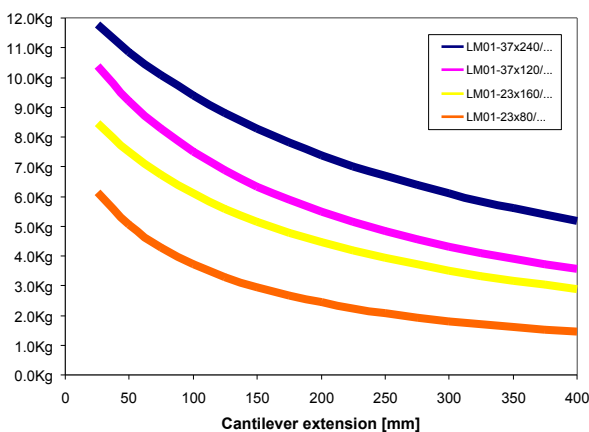

Cantilever extension is the maximum distance between the center of gravity of the payload and the face of the first ball bearing in the linear guide block.

Deflection [mm] in vertical direction without/with 10N payload in relation to the cantilever extension (module mounted horizontally).

Specifications of products are subject to change without notification.

Dimensions



Linear Modules LM01-23

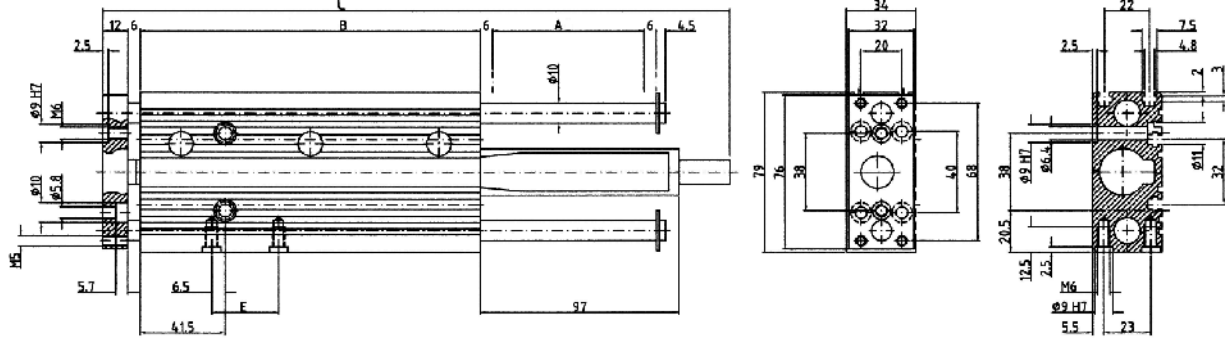

		LM01- 23x80/60	LM01- 23x80/160	LM01- 23x80/260	LM01- 23x160/80	LM01- 23x160/180	LM01- 23x160/280
Max. Stroke	A	60 (2.36)	160 (6.29)	260 (10.2)	80 (3.15)	180 (7.08)	280 (11.0)
Block length	B	86 (3.38)	86 (3.38)	86 (3.38)	166 (6.53)	166 (6.53)	166 (6.53)
Total length	C	210 (8.26)	290 (11.4)	440 (17.3)	310 (12.2)	440 (17.3)	500 (19.7)

mm (inch)

Linear Modules LM01-37

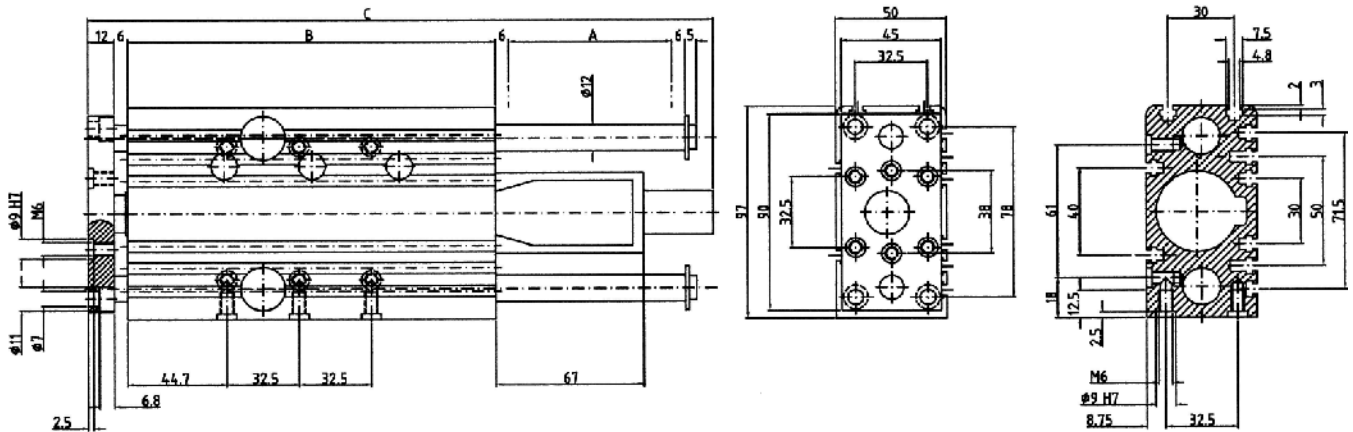

		LM01- 37x120/80	LM01- 37x120/180	LM01- 37x120/280	LM01- 37x240/60	LM01- 37x240/160	LM01- 37x240/260
Max. Stroke	A	80 (3.15)	180 (7.08)	280 (11.0)	60 (2.36)	160 (6.29)	260 (10.2)
Block Length	B	166 (6.53)	166 (6.53)	166 (6.53)	286 (11.3)	286 (11.3)	286 (11.3)
Total Length	C	320 (12.6)	415 (16.3)	520 (20.5)	415 (16.3)	520 (20.5)	620 (24.4)

mm (inch)

Servo Controller

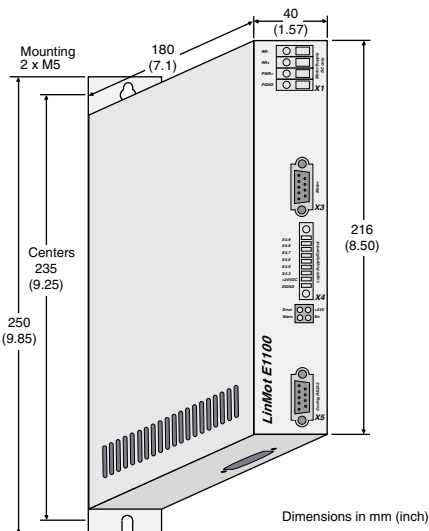

The cable length between Linear Motor and IP67 connector is 200mm (7.8 in). This cable has to be firmly mounted. The extension cables are high flex cables for use in cable tracks.

Power Supplies

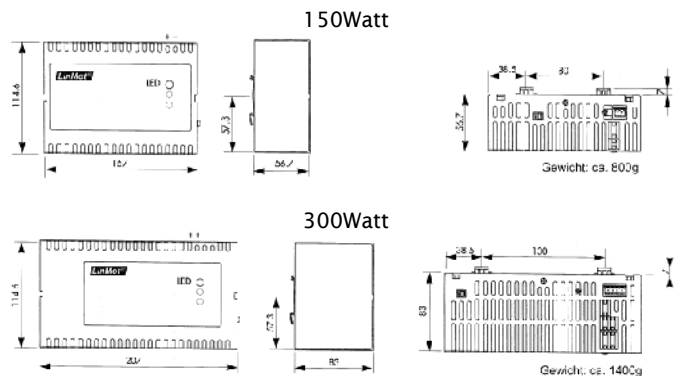

Linear Modules LM01

Type	IP67	Max. Stroke	Max. Force	Cont. Force	Max. Payload	Total Weight	Art.-No.
LM01-23x80/60	-M	60 (2.36)	44 (9.8)	9/16* (2.0/3.5*)	6.1 (13.5)	1.1 (2.4)	0150-5027
LM01-23x80/160	-M	160 (6.29)	44 (9.8)	9/16* (2.0/3.5*)	6.1 (13.5)	1.3 (2.9)	0150-5029
LM01-23x80/260	-M	260 (10.2)	44 (9.8)	9/16* (2.0/3.5*)	6.1 (13.5)	1.6 (3.5)	0150-5031
LM01-23x160/80	-M	80 (2.36)	60 (13.4)	17/31* (3.8/6.9*)	8.5 (18.7)	1.9 (4.2)	0150-5033
LM01-23x160/180	-M	180 (6.53)	60 (13.4)	17/31* (3.8/6.9*)	8.5 (18.7)	2.1 (4.6)	0150-5035
LM01-23x160/280	-M	280 (11.0)	60 (13.4)	17/31* (3.8/6.9*)	8.5 (18.7)	2.4 (5.3)	0150-5037
LM01-37x120/80	-M	80 (3.15)	80 (17.9)	30/54* (6.7/12*)	10.4 (23)	3.3 (7.3)	0150-5039
LM01-37x120/180	-M	180 (6.53)	80 (17.9)	30/54* (6.7/12*)	10.4 (23)	3.7 (8.2)	0150-5041
LM01-37x120/280	-M	280 (11.0)	80 (17.9)	30/54* (6.7/12*)	10.4 (23)	4.1 (9.1)	0150-5043
LM01-37x240/60	-M	60 (2.36)	160 (35.8)	55/100* (12/22*)	11.8 (26)	5.2 (11.5)	0150-5045
LM01-37x240/160	-M	160 (6.29)	160 (35.8)	55/100* (12/22*)	11.8 (26)	5.6 (12.4)	0150-5047
LM01-37x240/260	-M	260 (10.2)	160 (35.8)	55/100* (12/22*)	11.8 (26)	6.0 (13.3)	0150-5049
LMx01....	-M	...1'400 (55.1) mm (inch)	...500 (112) N (lbf)	120/220* (26/50*) *with fan N (lbf)	...25 (55) kg (lb)		kg (lb) on request

Servo Controllers E1100

Type	Description	Supply/Phase current	Art.-No.
E1100-MP	8 commands: abs. & rel. moves, teach, press	48-72VDC/4A	0150-1661
E1100-MT	256 commands: abs. & rel. moves, teach, press	48-72VDC/4A	0150-1663
E11xx	Profibus, DeviceNet, CANOpen, Sercos	48-72VDC/15A	on request

Motor Cable, Power Supplies & Options

Motor Cable	Description	Art.-No.
KS01-D/M-02	Motor cable 2m (8 in) with IP67 connector (high flex for use in trailing chains)	0150-1980
KS01-D/M-04	Motor cable 4m (16 in) with IP67 connector (high flex for use in trailing chains)	0150-1981
	other lengths on request	
Power Supplies		
S01-48/150	48V/150W for one module (slow movements)	input voltage 115/230VAC 0150-1940
S01-48/300	48V/300W for several modules (slow movements)	input voltage 115/230VAC 0150-1941
S01-72/300	72V/300W for one module (high dyn. movements)	input voltage 115/230VAC 0150-1942
S01-72/600	72V/600W for several modules (high dyn. movements)	input voltage 115/230VAC 0150-1943
T01-72/420	72VDC transformer supply (high dyn. movements)	input voltage 3x400VAC 0150-1966
T01-72/420-USA	72VDC transformer supply (high dyn. movements)	input voltage 3x240VAC 0150-1967
Optional Fan		
HV01-23	Fan for Linear Module LM01-23	0150-5050
HV01-37	Fan for Linear Module LM01-37	0150-5051
Optional Mechanical Brake		
HB01-37	Clamping unit for Linear Modul LM01-37	0150-5052
		see MagSpring brochure
Option MagSpring		

LinMot products are available from more than 80 distributors world wide. Ask us for the distribution nearest to you:

NTI Ltd. Tel.: +41(0)56 419 91 91
 LinMot Fax.: +41(0)56 419 91 92
 Haerdlistrass 15 Mail: office@LinMot.com
 CH-8957 Spreitenbach Net: www.LinMot.com
 S witzerland

LinMot Inc. Tel.: 877 546 3270
 N2444 Broad Street 262-728-2699
 Delavan Fax.: 800 463 8708
 WI 53115 Mail: officeUS@LinMot.com
 USA



Specifications of products are subject to change without notification.